



LM Actuator

THK General Catalog

A Technical Descriptions of the Products

Model GL

Structure and features.....	A-438
• Feature of the LM Actuator Model GL..	A-438
Structure and features	A-438
• Types of the LM Actuator Model GL	A-440
Types and Features.....	A-440
Point of Selection	A-442
• Load Rating.....	A-442
• Maximum Travel Speed	A-443
• Accuracy Standards.....	A-443
Options	A-444
• Cover	A-444
• Bellows	A-445
• Endplate	A-445
• Sensor.....	A-445
• Plate Nut for Mounting the Base	A-445
Precautions on Use	A-446

B Product Specifications (Separate)

Dimensional Drawing, Dimensional Table

Model GL.....	B-347
• Ball Screw Drive Type	
Long table type of model GL15	B-348
Short table type of model GL15	B-349
Long table type of model GL20	B-350
Short table type of model GL20	B-351
• Belt Drive Type	
Long table type of model GL15	B-352
Short table type of model GL15	B-353
Long table type of model GL20	B-354
Short table type of model GL20	B-355
• Model Number Coding	B-356
Options.....	B-358
• Bellows.....	B-358
• Endplate	B-362
• Plate Nut for Mounting the Base	B-362

* Please see the separate "B Product Specifications".

Feature of the LM Actuator Model GL

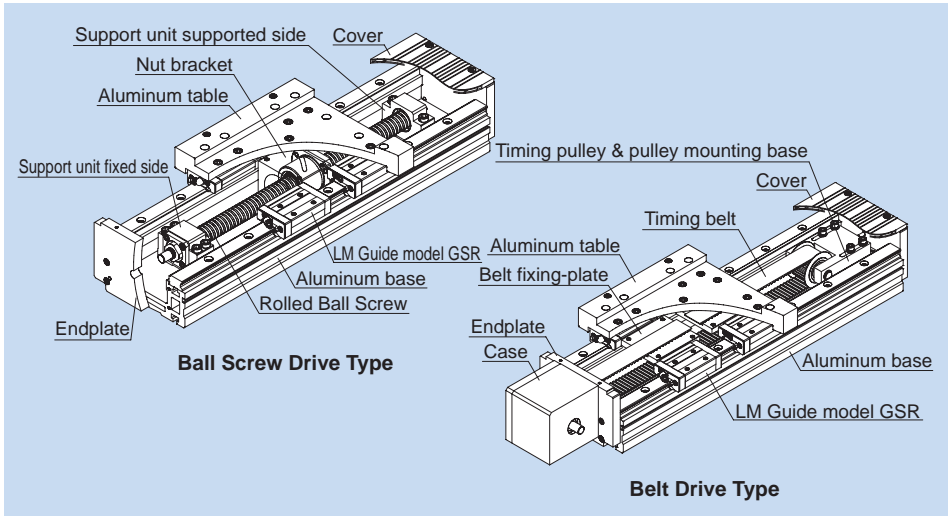

Fig.1 Structures of the Ball Screw Drive Type of Model GL and the Belt Drive Type of Model GL

Structure and Features

Model GL is a single-axis actuator that allows a ball screw drive or a belt drive to be integrated with an aluminum base on which the LM Guide model GSR is mounted. For the ball screw drive type of model GL, several ball screw leads are available to select from. The belt drive type of model GL supports a long stroke.

Model GL is used mainly in conveyance-related applications.

[Drive Methods are Selectable]

With model GL, two drive types are available to select from: a ball screw drive type and a belt drive type

- Ball screw specifications
Different ball screw leads are selectable for each model number.

- Belt drive type
Since it uses a highly rigid belt (wire woven), this type excels in high speed operation, and is not subject to restriction by dangerous speed as opposed to ball screw type. Therefore, it supports a longer stroke (up to 2720 mm for model GL20) than ball screw type. In addition, this type uses a timing pulley with different pitch circle diameter according to the model number.

Table1 Ball Screw Leads by Model Numbers

	Ball Screw lead (mm)
GL 15	5, 16, 30
GL 20	5, 20, 40

Table2 Pitch Circle Diameter of the Timing Pulley

	Pitch circle diameter (P.C.D) (mm)
GL 15	35.01
GL 20	38.20

Note) When using AC servomotor drive, we recommend also using a reducer. For details, contact THK.

[Lightweight, High Rigidity]

The base using an extruded aluminum material has a hollow sectional shape, thus achieving lightweight and high rigidity.

Table3 Geometrical Moment of Inertia and Mass of the Aluminum Base

	Geometrical moment of inertia		Mass (kg/1000mm)
	I_x (mm ⁴)	I_y (mm ⁴)	
GL15	2.0×10^5	2.7×10^5	5.1
GL20	4.62×10^5	4.62×10^5	6.8

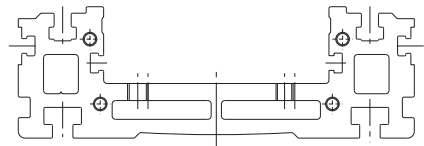

GL15

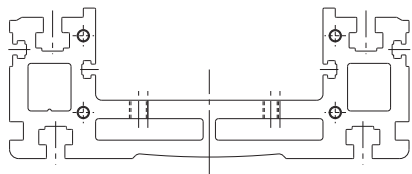

GL20

Fig.2 Cross Section of the Aluminum Base

Types of the LM Actuator Model GL

Types and Features

[Ball Screw Drive Type]

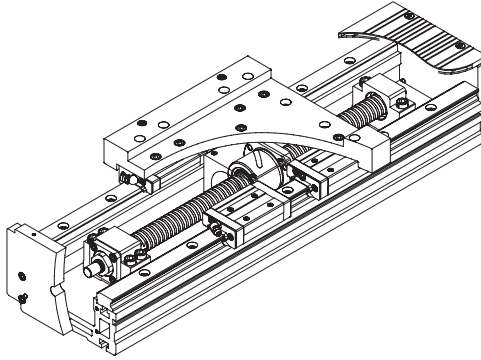

Long Table

This type has 4 units of LM Guide model GSR --- T (long type) attached with a dedicated table.

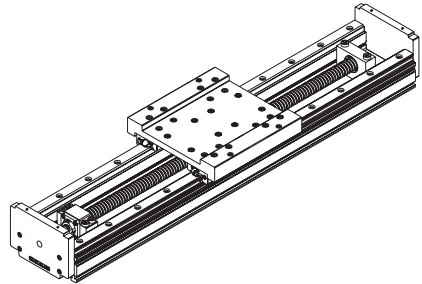

Short Table

This type has 4 units of LM Guide model GSR --- V (short type) attached with a dedicated table.

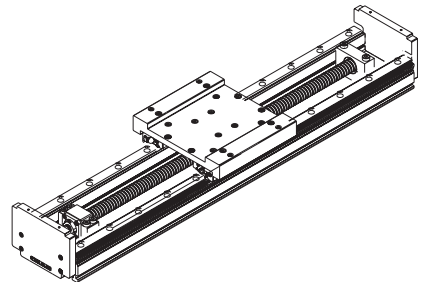

dammy

dammy

[Belt Drive Type]

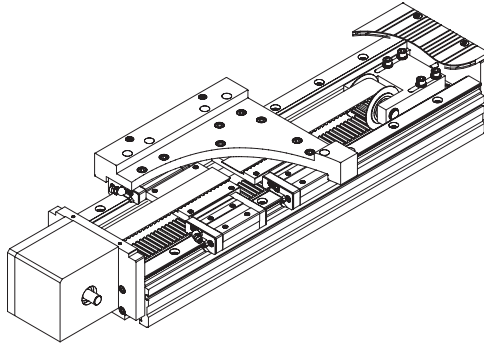

LM Actuator

Long Table

This type has 4 units of LM Guide model GSR --- T (long type) attached with a dedicated table.

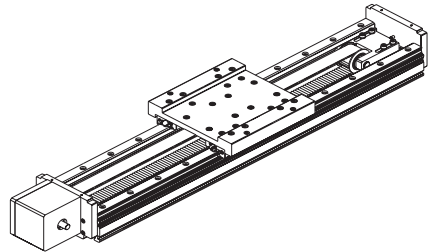

Short Table

This type has 4 units of LM Guide model GSR --- V (short type) attached with a dedicated table.

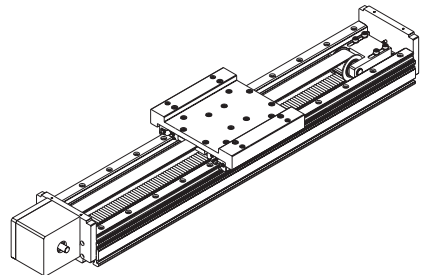

Load Rating

The following table shows the load ratings of the LM Guide, the Ball Screw and the support bearing used in model GL, which will help select a specific GL model.

[LM Guide Unit]

Model GL uses LM Guide model GSR for its guide unit.

Table1 shows the load ratings of the LM Guide model GSR used in model GL.

Table1 Load Rating of an LM Guide

	Model No.	Basic dynamic load rating C (kN)	Basic static load rating C0 (kN)
GL 15	GSR 15V	4.31	5.59
	GSR 15T	5.69	8.43
GL 20	GSR 20V	7.01	8.82
	GSR 20T	9.22	13.2

[Ball Screw Unit]

The ball screw drive type of model GL uses a THK Ball Screw for its ball screw unit.

Table2 shows the load ratings of the ball screw used in the ball screw drive type of model GL.

Table2 Load Ratings of the Ball Screw Unit

	Model No.	Basic dynamic load rating Ca (kN)	Basic static load rating C0a (kN)
GL 15	BTK1605-2.6ZZ	5.4	13.3
	BLK1616-3.6ZZ	10.5	25.9
	WTF1530-2ZZ	5.6	12.4
GL 20	BTK2005-2.6ZZ	6	16.5
	BLK2020-3.6ZZ	7.7	22.3
	WTF2040-2ZZ	5.4	13.6

[Support Bearing Unit]

The ball screw drive type of model GL uses a THK Ball Screw for its ball screw unit.

Table3 shows the load ratings of the ball screw used in the ball screw drive type of model GL.

Table3 Load Ratings of and the Static Permissible Load of the Support Bearing Unit

	Model No.	Basic dynamic load rating Ca (N)	Static permissible load P _{0a} (N)
GL 15	GK 10	6080	2100
GL 20	GK 12	6660	2200

Maximum Travel Speed

The maximum travel speed of the ball screw drive type of model GL is limited by the DN value of and the dangerous speed of the ball screw regardless of the maximum rotation speed of the motor.

Table4 Maximum Travel Speed Unit: mm/sec

Base length (mm)	GL 15			GL 20		
	Lead (mm)			Lead (mm)		
	5	16	30	5	20	40
340	248	1120	2220	—	—	—
460	248	1120	2220	203	740	2247
580	248	1120	2220	203	740	2247
700	248	1120	2220	203	740	2247
820	248	1120	2120	203	707	2247
1060	203	667	1145	203	382	2127
1240	141	464	795	180	265	1480
1420	104	341	585	133	195	1087
1600	—	—	—	102	150	833
1780	—	—	—	81	118	660

Accuracy Standards

The accuracy of model GL is defined in terms of positioning repeatability.

[Positioning Repeatability]

After repeating positioning to a given point in the same direction seven times, measure the halting point and obtain the value of half the maximum difference. Perform this measurement in the center and both ends of the travel distance, use the maximum value as the measurement value and express the value of half the maximum difference with symbol "±" as positioning repeatability.

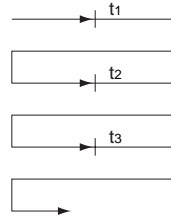

Fig.1 Positioning Repeatability

Table5 Accuracy of Each Model Unit: mm

Drive method	Model No.	
	GL 15	GL 20
Ball screw	±0.02	±0.02
Belt	±0.08	±0.08

Various types of options are available for model GL. Select an appropriate model according to your application.

Name	Reference page	Overview
Cover	A-444	Serve as contamination protection accessories or the likes
Bellows	A-445	
Endplate	A-445	For ball screw drive type
Sensor	A-445	Proximity sensor, photo sensor
Plate nut for mounting the base	A-445	Used for securing the base mounting bolt

Cover

For model GL, a cover is available for contamination protection from entering the top face.

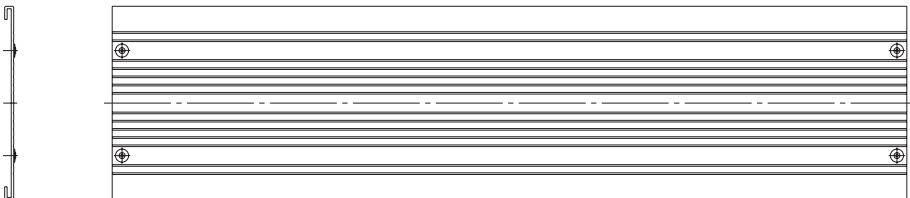
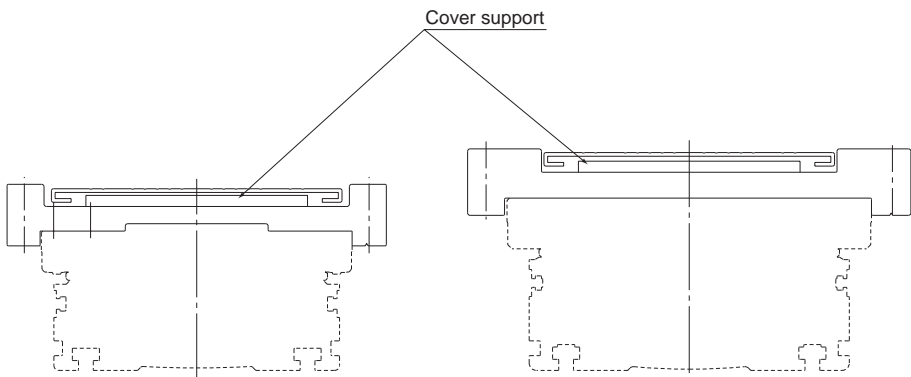

Fig.1 Outline Drawing of the Cover

* Greater the base length, the greater the deflection of the cover. To prevent the cover from deflecting, attach a cover support on the table (see figure below). The cover is attached as standard for models with a base length of 1060 mm or longer.



Model GL15

Model GL20

Cross section of the cover support

Bellows

●For dimensions of the bellows, see B-358 to B-361.

For model GL, a bellows is available for contamination protection in addition to a cover.

Endplate

●For detailed dimensions, see B-362.

With the ball screw drive type of model GL, the end plate on the motor mounting side is machined according to the motor used. Indicate the motor to be used when placing an order to THK.

Sensor

Various types of sensors can be mounted for model GL. Contact THK for details.

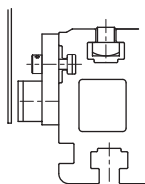

GXL-N12F

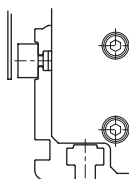

TL-W3MC1

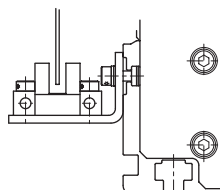

EE-SX671

Proximity sensor	GXL-N12F (SUNX) TL-W3MC1 (Omron)
Photo micro sensor	EE-SX671 (Omron)

Plate Nut for Mounting the Base

●For detailed dimensions, see B-362.

For model GL, a plate nut for mounting the base is available. It is attached as standard when mode GL is delivered.

[Handling]

- (1) Disassembling parts may cause foreign material to enter the system or deteriorate the accuracy. Do not disassemble the product.
- (2) Dropping or hitting the LM Actuator model GL may damage it. Giving an impact to the Slide Rail could also cause damage to its function even if the product looks intact.

[Lubrication]

- (1) Thoroughly remove anti-rust oil and feed lubricant before using the product.
- (2) Do not mix lubricants of different physical properties.
- (3) In locations exposed to constant vibrations or in special environments such as clean rooms, vacuum and low/high temperature, normal lubricants may not be used. Contact THK for details. For clean room applications, low dust-generative grease is available. Contact THK for details.
- (4) When planning to use a special lubricant, contact THK before using it.
- (5) To maximize the performance of the LM Actuator model GL, lubrication is required. Using the product without lubrication may increase wear of the rolling elements or shorten the service life.
- (6) In normal use, the lubricant must be replenished every 100 km as a guide. However, the greasing interval varies according to the conditions. We recommend determining the greasing interval based on the result of the initial inspection.

[Precautions on Use]

- (1) Entrance of foreign material may cause damage to the ball circulating component or functional loss. Prevent foreign material, such as dust or cutting chips, from entering the system.
- (2) When planning to use the LM system in an environment where the coolant penetrates the LM Actuator model GL, it may cause trouble to product functions depending on the type of the coolant. Contact THK for details.
- (3) Do not use the product at temperature of 80 °C or higher. Contact THK if you desire to use the product at a temperature of 80°C or higher.
- (4) When using the LM system in locations exposed to constant vibrations or in special environments such as clean rooms, vacuum and low/high temperature, contact THK in advance.
- (5) Exceeding the permissible rotational speed may lead the components to be damaged or cause an accident. Be sure to use the product within the specification range designated by THK.

[Storage]

When storing the LM Actuator model GL, enclose it in a package designated by THK and store it in a horizontal orientation while avoiding high temperature, low temperature and high humidity.