

Tilt Stage 40 x 40

Complex coupling method

0.75 A/phase motor

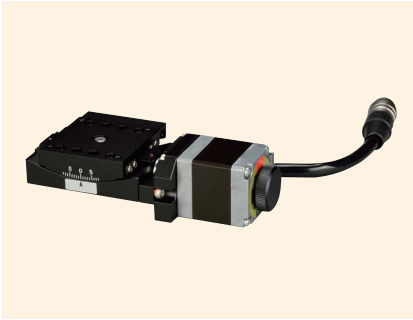

↑ TATS-C416C-HM



↑ TATS-C412C-HM

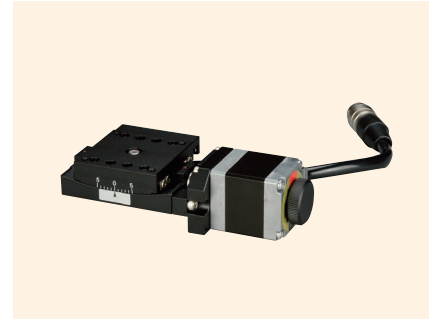

↑ TATS-C410C-HM



↑ TATD-C412C-HM

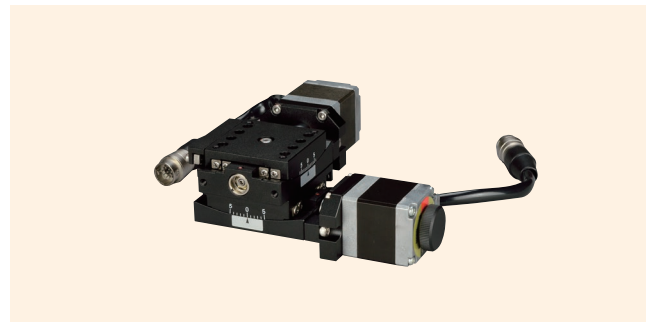

↑ TATD-C410C-HM

Features

- A tilt stage with differing rotation center height and travel amount.
- The proprietary complex coupling structure enables fine movements to be made extraordinarily smoothly.
- Versatile use for precision positioning of cameras, sensors, etc.

Model number	TATS-C416C-HM	TATS-C412C-HM	TATS-C410C-HM	TATD-C412C-HM	TATD-C410C-HM
Model name	Tilt Stage			2-Axis Tilt Stage	
Travel direction	Tilt single direction			Tilt double direction	
Stage height	18 mm			36 mm	
Rotation center (from stage top)	50 mm	68 mm	86 mm	50 mm	68 mm
Travel amount	±8°	±6°	±5°	Upper axis ±8°/lower axis ±6°	Upper axis ±6°/lower axis ±5°
Stage surface	40 mm x 40 mm				
Motor used	PK523HPB equivalent (5-wire type pentagonal wiring, 0.75 A/phase)				
Resolution	0.000939°	0.000725°	0.000591°	Upper axis 0.000939°/ lower axis 0.000725°	Upper axis 0.000725°/ lower axis 0.000591°
Feed screw lead	0.5 mm				
Travel guide	V-groove and cross rollers				
Travel mechanism/feed type	Complex coupling/feed screw				
Positioning accuracy	0.03°				
Rotation center accuracy	φ 0.05 mm			-	
Repeatability	±0.002°				
Lost motion	0.006°				
Load capacity	29.4 N (3 kgf)			19.8 N (2 kgf)	
Mass	0.4 kg			0.8 kg	
Maximum speed (at 5,000 pps)	4.7°/s	3.6°/s	3°/s	Upper axis 4.7°/s, lower axis 3.6°/s	Upper axis 3.6°/s, lower axis 3.0°/s
Main materials/surface treatment	Aluminum alloy/black satin anodized finish				
Home position sensor	Normally closed contact (break contact, B contact) operation, photo sensor				
Pre-home sensor	-				
Limit sensor	Normally closed contact (break contact, B contact) operation, photo sensor				
Applicable cables	TACB-BTM-D3, TARC-BTM-D3				
RoHS directive compliance status	RoHS2 Regulation 10 substances do not contain				



Motorized Stages
Automated Products for Microscopes
Manual Stages
High-Grade Stages (40 mm x 30 mm) Compact Stages
Cross Roller Stages
Ball Bushing Stages
High-Precision/High-Rigidity Stages
Z-Lift Stages
Tilt Stages
Correction Cables
Actuators



Tilt Stages ◀ Motorized Stages ◀

Product Appearance

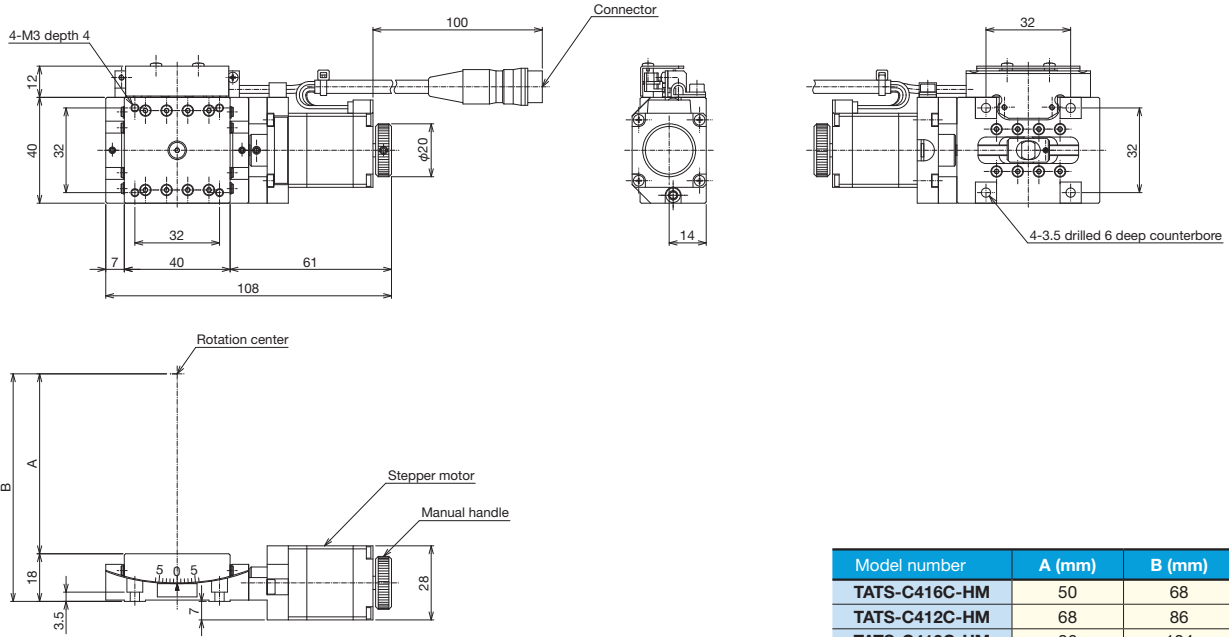

Model number	A (mm)	B (mm)
TATS-C416C-HM	50	68
TATS-C412C-HM	68	86
TATS-C410C-HM	86	104

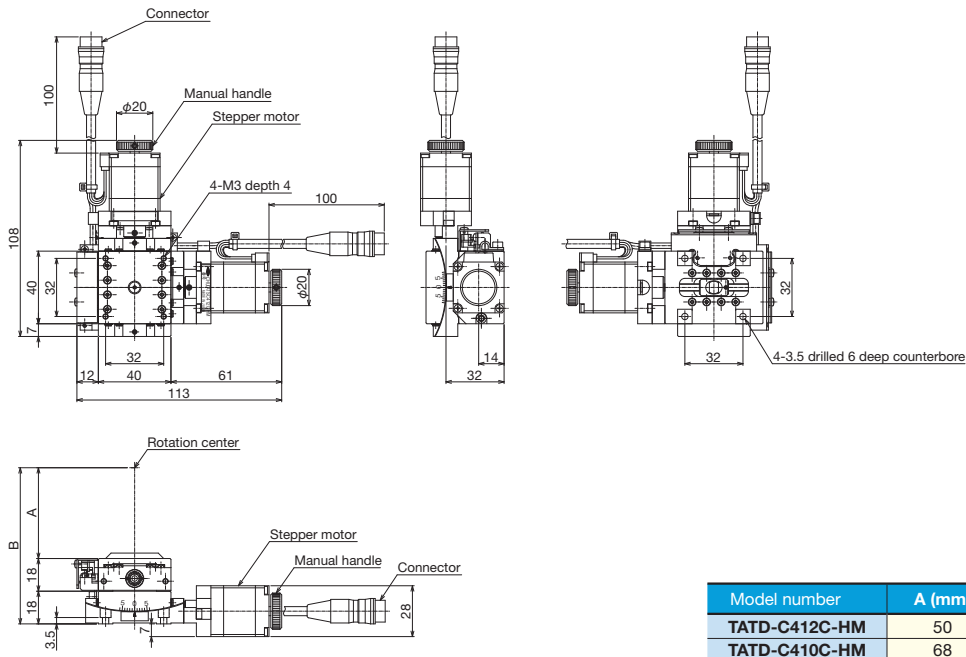

Model number	A (mm)	B (mm)
TATD-C412C-HM	50	86
TATD-C410C-HM	68	104

◆ Sensor operating logic and timing chart

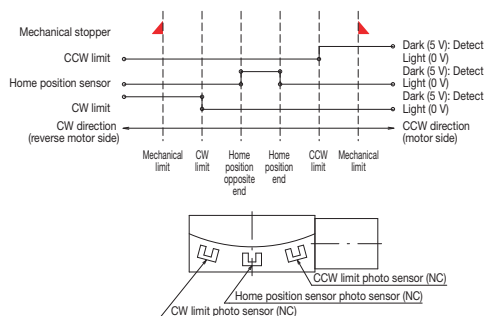

◆ Connection method: Connection cable and driver

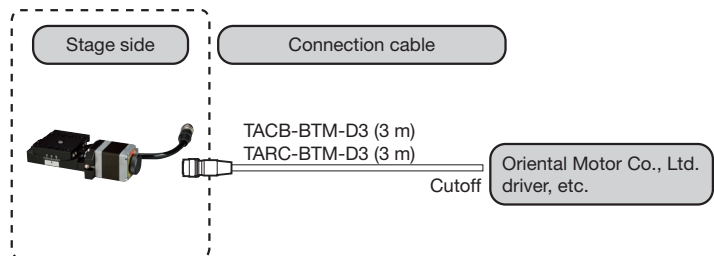

- Motorized Stages
- Automated Products for Microscopes
- Manual Stages
- High-Grade Stages
- 30 mm x 30 mm (φ30 mm) Compact Stages
- Class Roller Stages
- Ball Bushing Stages
- High-Precision/High-Rigidity Stages
- Z-Limit Stages
- Tilt Stages
- Connection Cables
- Actuators

Tilt Stage 60 x 60

Complex coupling method

0.75 A/phase
0.75 A/phase motor



↑ TATS-C616C-HM



↑ TATS-C612C-HM



↑ TATS-C610C-HM



↑ TATD-C612C-HM



↑ TATD-C610C-HM

Features

- A tilt stage with differing rotation center height and travel amount.
- The proprietary complex coupling structure enables fine movements to be made extraordinarily smoothly.
- Versatile use for precision positioning of cameras, sensors, etc.

Model number	TATS-C616C-HM	TATS-C612C-HM	TATS-C610C-HM	TATD-C612C-HM	TATD-C610C-HM
Model name	Tilt Stage			2-Axis Tilt Stage	
Travel direction	Tilt single direction			Tilt double direction	
Stage height	26 mm			52 mm	
Rotation center (from stage top)	70 mm	96 mm	122 mm	70 mm	96 mm
Travel amount	±8°	±6°	±5°	Upper axis ±8°/ lower axis ±6°	Upper axis ±6°/ lower axis ±5°
Stage surface	60 mm x 60 mm				
Motor used	PK523HPB equivalent (5-wire type pentagonal wiring, 0.75 A/phase)				
Resolution	0.000666°	0.000512°	0.000415°	Upper axis 0.000666°/ lower axis 0.000512°	Upper axis 0.000512°/ lower axis 0.000415°
Feed screw lead	0.5 mm				
Travel guide	V-groove and cross rollers				
Travel mechanism/feed type	Complex coupling/feed screw				
Positioning accuracy	0.03°				
Rotation center accuracy	φ0.05 mm			-	
Repeatability	±0.002°				
Lost motion	0.006°				
Load capacity	49 N (5 kgf)			29.4 N (3 kgf)	
Mass	0.6 kg			1.2 kg	
Maximum speed (at 5,000 pps)	3.3°/s	2.6°/s	2.1°/s	Upper axis 3.3°/s, lower axis 2.6°/s	Upper axis 2.6°/s, lower axis 2.1°/s
Main materials/surface treatment	Aluminum alloy/black satin anodized finish				
Home position sensor	Normally closed contact (break contact, B contact) operation, photo sensor				
Pre-home sensor	-				
Limit sensor	Normally closed contact (break contact, B contact) operation, photo sensor				
Applicable cables	TACB-BTM-D3, TARC-BTM-D3				
RoHS directive compliance status	RoHS2 Regulation 10 substances do not contain				



Tilt Stages ◀ Motorized Stages ▶

Product Appearance

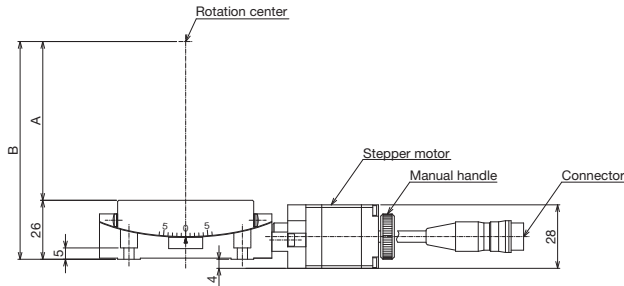
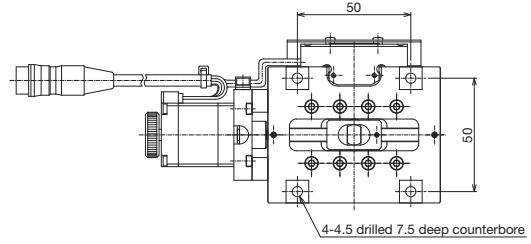
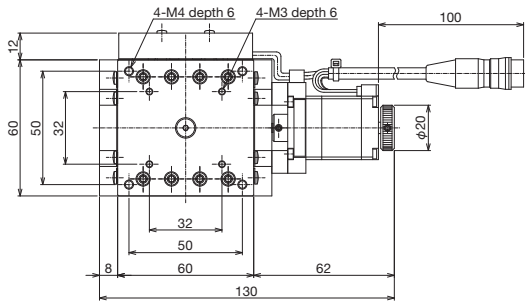

Model number	A (mm)	B (mm)
TATS-C616C-HM	70	96
TATS-C612C-HM	96	122
TATS-C610C-HM	122	148

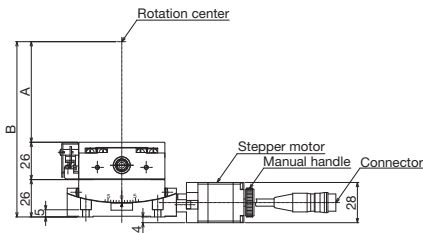
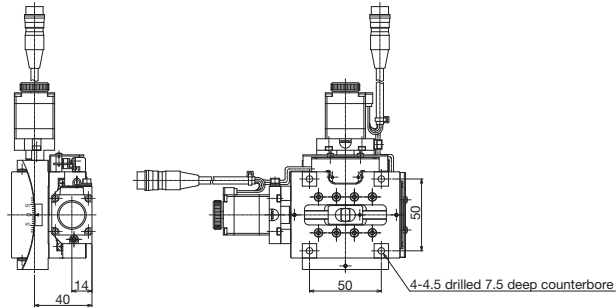
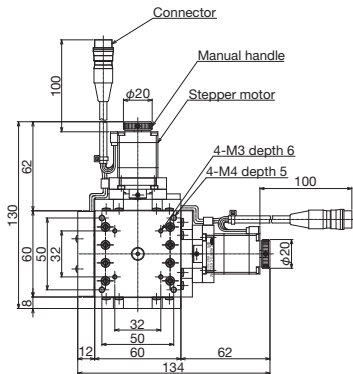

Model number	A (mm)	B (mm)
TATD-C612C-HM	70	122
TATD-C610C-HM	96	148

◆ Sensor operating logic and timing chart

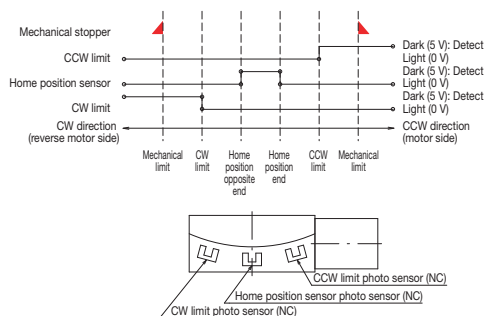

◆ Connection method: Connection cable and driver

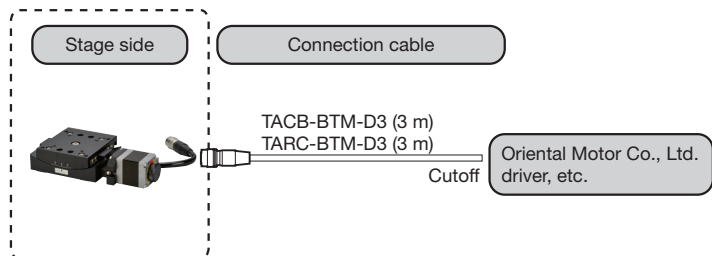

- Motorized Stages
- Automated Products for Microscopes
- Manual Stages
- High-Grade Stages
- 30 mm x 30 mm (ø30 mm) Compact Stages
- Class Roller Stages
- Ball Bushing Stages
- High-Precision/High-Rigidity Stages
- Z-Lift Stages
- Tilt Stages
- Connection Cases
- Actuators

Tilt Stage 90 x 90

0.75 A/phase 0.75 A/phase motor

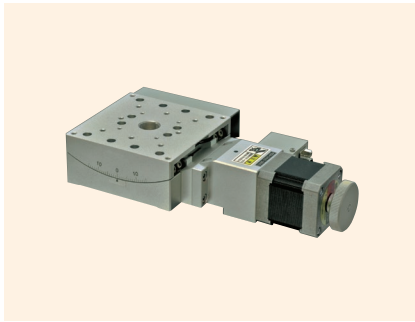

↑ TATS-9030-HP

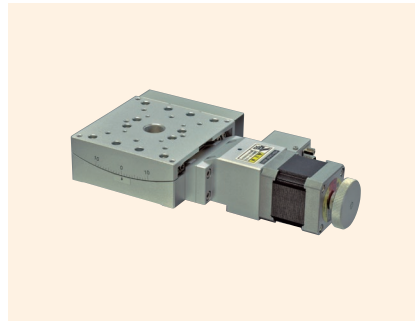

↑ TATS-9020-HP

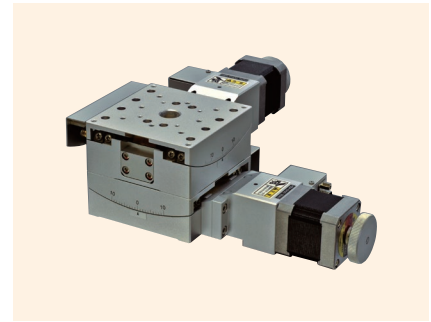

↑ TATD-9020-HP

Features

- A tilt stage possessing a rotation center above the space.
- Uses V-groove and cross rollers (V-CR method) for the travel guides.
- Versatile use for precision positioning of cameras, sensors, etc.

Model number	TATS-9030-HP	TATS-9020-HP	TATD-9020-HP
Model name	Tilt Stage		2-Axis Tilt Stage
Travel direction	Tilt single direction		Tilt double direction
Stage height	40 mm	36 mm	76 mm
Rotation center (from stage top)	72 mm	112 mm	72 mm
Travel amount	±15°	±10°	Upper axis ±15°/lower axis ±10°
Stage surface	90 mm x 90 mm		
Motor used	PK545NBW equivalent (5-wire type pentagonal wiring, 0.75 A/phase)		
Resolution	0.002°		
Travel guide	V-groove and cross rollers		
Travel mechanism, feed type	Worm gear		
Positioning accuracy	0.025°		
Rotation center accuracy	φ 0.05 mm		-
Repeatability	±0.002°		
Lost motion	0.002°		
Moment rigidity	Yaw rigidity 0.4 s/N-cm, roll rigidity 0.1 s/N-cm		Yaw rigidity 0.8 s/N-cm
Load capacity	58.8 N (6 kgf)		49 N (5 kgf)
Mass	1.6 kg	1.5 kg	3.1 kg
Maximum speed (at 5,000 pps)	10°/s		
Main materials/surface treatment	Aluminum alloy/white satin anodized finish		
Home position sensor	Normally open contact (make contact, A contact) operation, photo sensor		
Pre-home sensor	Normally closed contact point (break contact, B contact) operation, photo sensor		
Limit sensor	Normally closed contact point (break contact, B contact) operation, photo sensor		
Applicable cables	TACB-BTD-D3, TARC-BTD-D3		
RoHS directive compliance status	RoHS2 Regulation 10 substances do not contain		

◆ Sensor operating logic and timing chart

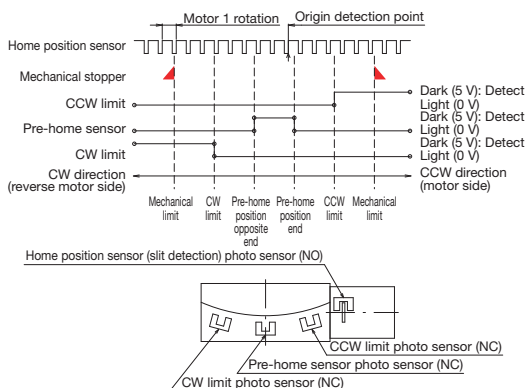

◆ Connection method: Connection cable and driver

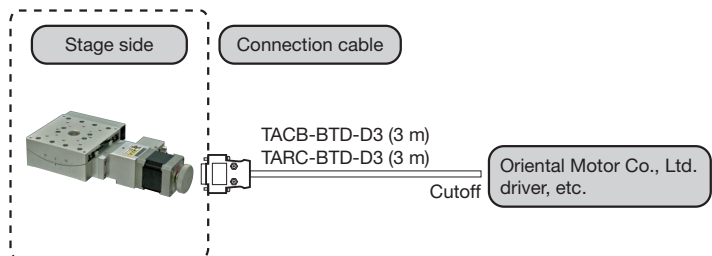



Tilt Stages ◀ Motorized Stages ◀

Product Appearance

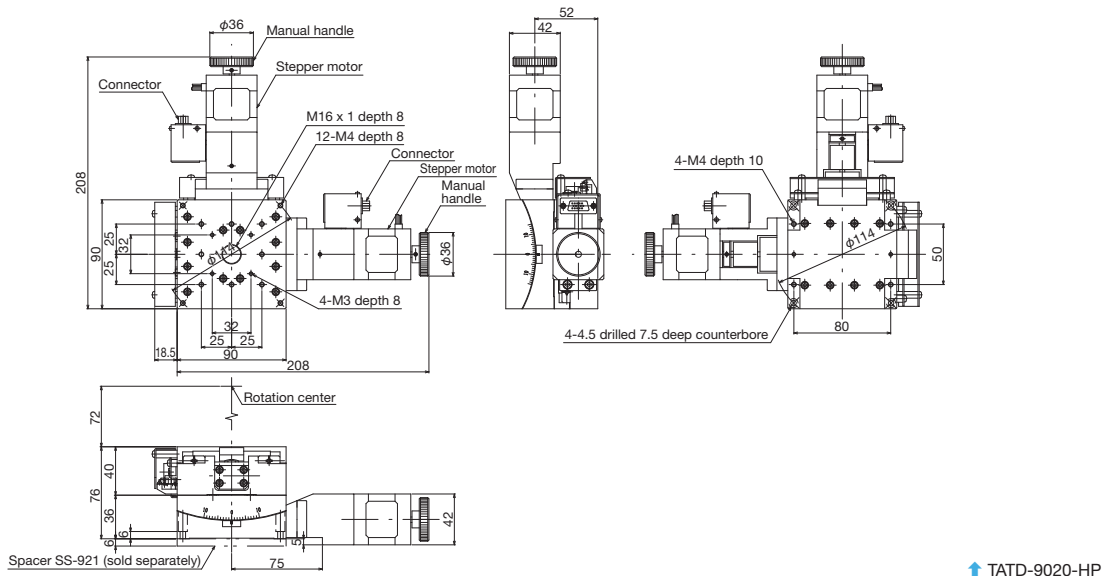
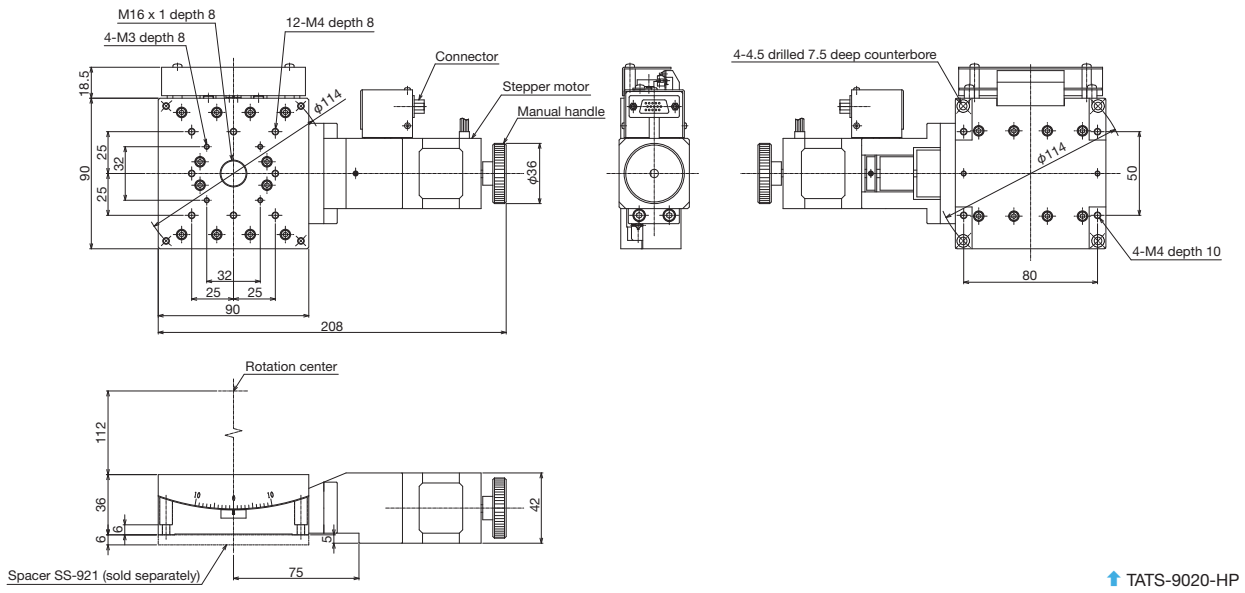
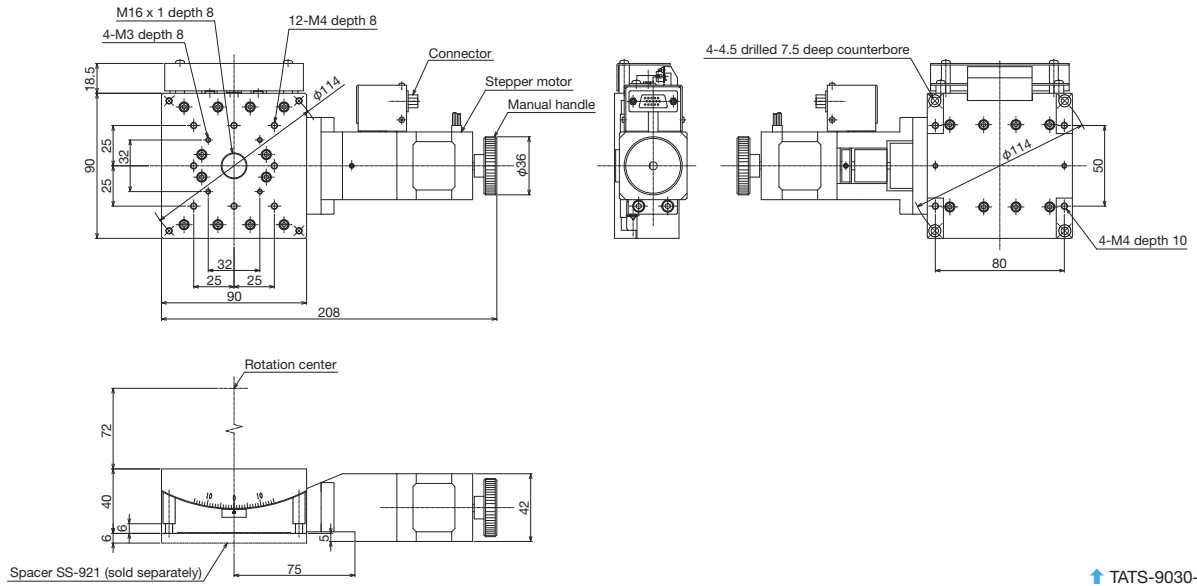

Motorized Stages	Automated Products for Microscopes	Manual Stages	High-Grade Stages	30 mm x 30 mm (or 30 mm) Coarse Stages	Coarse Roller Stages	Ball Bushing Stages	High-Precision/High-Rigidity Stages	Z-Lift Stages	Tilt Stages	Connection Clamps	Actuators
------------------	------------------------------------	---------------	-------------------	--	----------------------	---------------------	-------------------------------------	---------------	-------------	-------------------	-----------

Tilt Stage 125 x 125

0.75 A/phase 0.75 A/phase motor

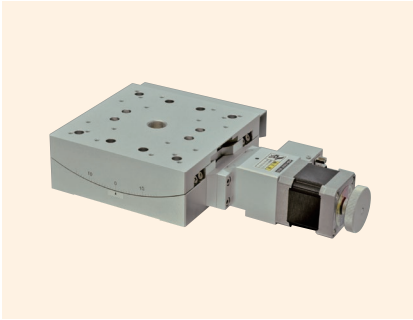

↑ TATS-1230-HP

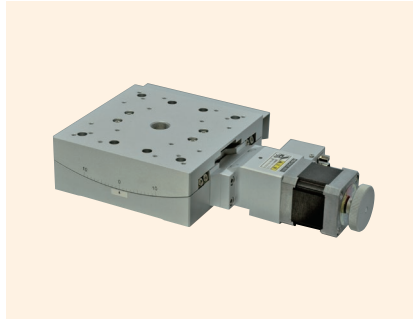

↑ TATS-1220-HP

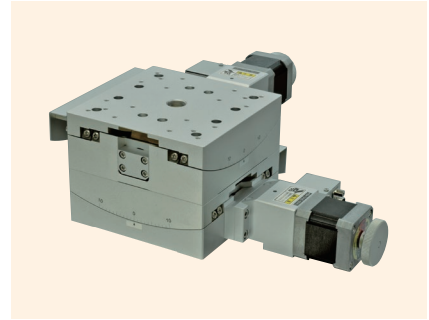

↑ TATD-1220-HP

Features

- A tilt stage possessing a rotation center above the space.
- Uses V-groove and cross rollers (V-CR method) for the travel guides.
- Versatile use for precision positioning of cameras, sensors, etc.

Model number (standard)	TATS-1230-HP	TATS-1220-HP	TATD-1220-HP
Model name	Tilt Stage		2-Axis Tilt Stage
Travel direction	Tilt single direction		Tilt double direction
Stage height	48 mm	47 mm	95 mm
Rotation center (from stage top)	112 mm	160 mm	112 mm
Travel amount	±15°	±10°	Upper axis ±15°/lower axis ±10°
Stage surface	125 mm x 125 mm		
Motor used	PK545NBW equivalent (5-wire type pentagonal wiring, 0.75 A/phase)		
Resolution	0.002°		
Travel guide	V-groove and cross rollers		
Travel mechanism, feed type	Worm gear		
Positioning accuracy	0.025°		
Rotation center accuracy	φ 0.05 mm		-
Repeatability	±0.002°		
Lost motion	0.002°		
Moment rigidity	Yaw rigidity 0.08 s/N-cm, roll rigidity 0.03 s/N-cm		Yaw rigidity 0.16 s/N-cm
Load capacity	98 N (10 kgf)		78.4 N (8 kgf)
Mass	2.7 kg		5.4 kg
Maximum speed (at 5,000 pps)	10°/s		
Main materials/surface treatment	Aluminum alloy/white satin anodized finish		
Home position sensor	Normally open contact (make contact, A contact) operation, photo sensor		
Pre-home sensor	Normally closed contact point (break contact, B contact) operation, photo sensor		
Limit sensor	Normally closed contact point (break contact, B contact) operation, photo sensor		
Applicable cables	TACB-BTD-D3, TARC-BTD-D3		
RoHS directive compliance status	RoHS2 Regulation 10 substances do not contain		

◆ Sensor operating logic and timing chart

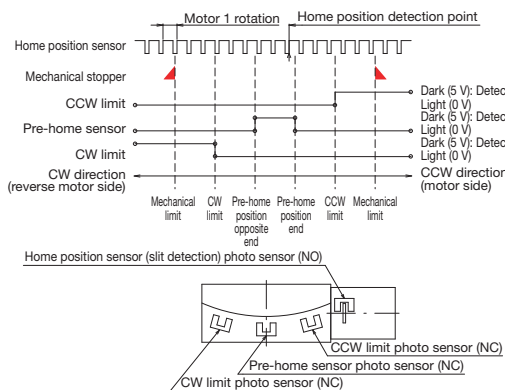

◆ Connection method: Connection cable and driver

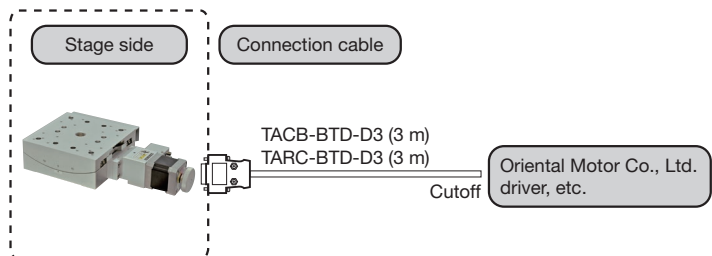



Tilt Stages ◀ Motorized Stages ◀

Product Appearance

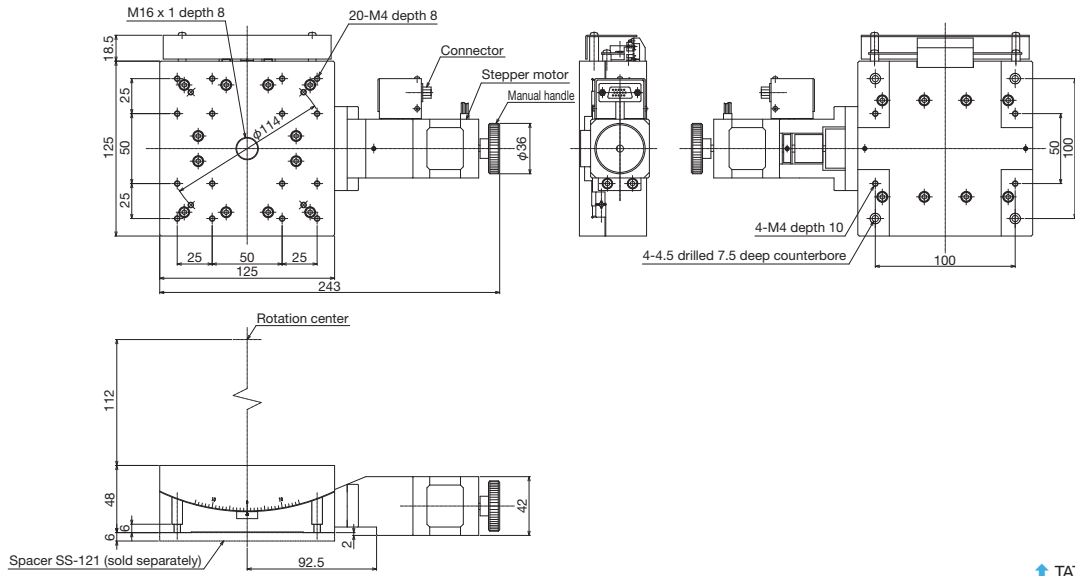

↑ TATS-1230-HP

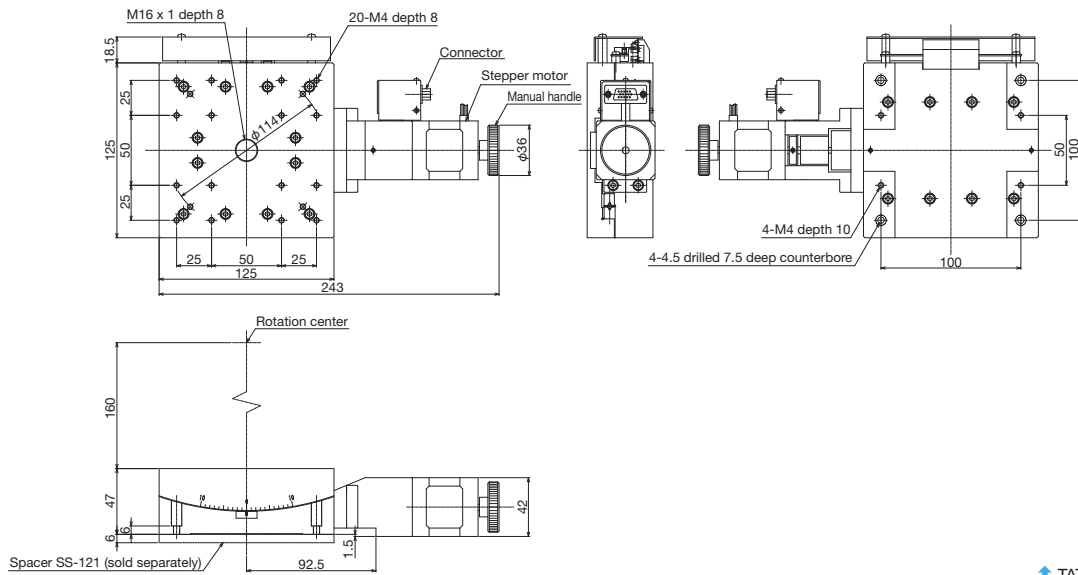

↑ TATS-1220-HP

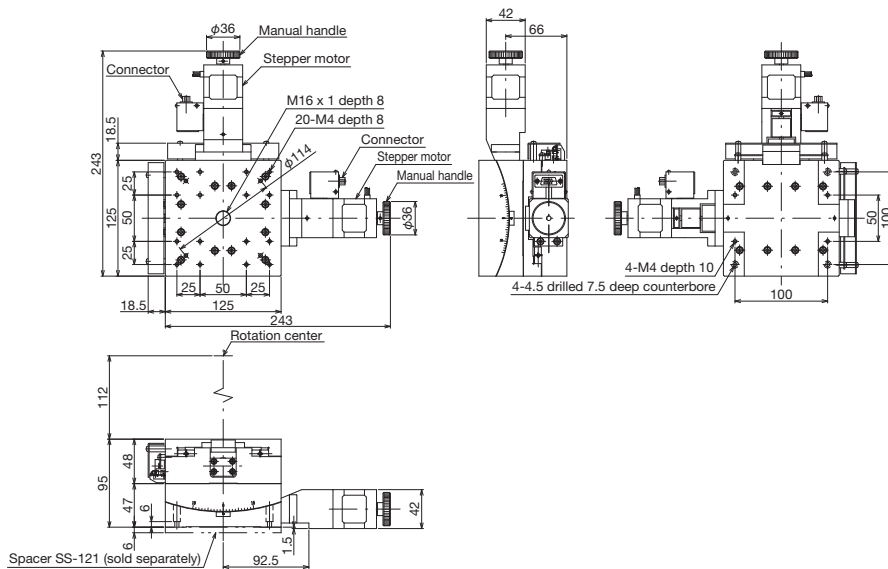

↑ TATD-1220-HP

Motorized Stages	Automated Products for Microscopes	Manual Stages	High-Grade Stages	30 mm x 30 mm (φ30 mm) Connector Stages	Crash Roller Stages	Ball Bushing Stages	High-Precision/High-Rigidity Stages	Z-Lift Stages	Tilt Stages	Connection Cases	Actuators
------------------	------------------------------------	---------------	-------------------	---	---------------------	---------------------	-------------------------------------	---------------	-------------	------------------	-----------

Driver Connection Cable

0.75 A/phase 0.75 A/phase motor

Features

- Driver connection cables are only wired to stage side connectors.

Model number	TACB-BTD-D3	TACB-BTM-D3
Model name	Driver connection cable 3 m	

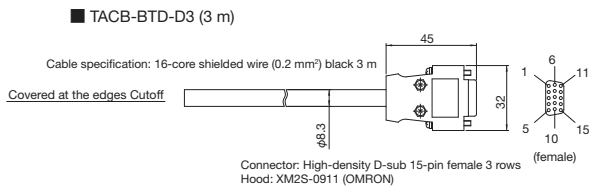

Lead color	No	Stage side
Brown	1	Blue motor lead B
Blue	2	Red motor lead D
Gray	3	Orange motor lead A
Orange	4	Green motor lead C
Pink	5	Black motor lead E
light blue	6	Sensor Vcc
Purple	7	CW limit
Green	8	CCW limit
Yellow	9	Sensor GND
Red	10	Home position sensor
White	11	Pre-home sensor
White/Blue	12	unused
White/Red	13	Brake control
White/Green	14	Brake control
Shield	15	FG

(Do not use this line)

Dotted line is the shield.

Compatible motorized stages

TALS-○○○-E○P○
 TALS-○○○-H○P○
 TALS-○○○-H1S
 TALD-○○○-E○P○
 TALD-○○○-H○P○
 TALD-○○○-H1S
 TALZ-○○○-E○P○
 TALZ-○○○-H○P○
 TALZ-○○○-H1S
 TALV-○○○-H○P
 TARS-○○○-HP
 TATS-○○○-HP
 TATD-○○○-HP

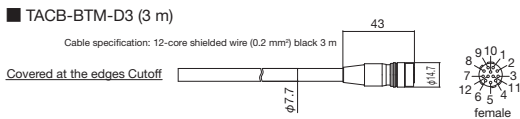

Lead color	No	Stage side
Brown	1	Blue motor lead B
Blue	2	Red motor lead D
Gray	3	Orange motor lead A
Orange	4	Green motor lead C
Pink	5	Black motor lead E
light blue	6	Sensor Vcc
Purple	7	CW limit
Green	8	CCW limit
Yellow	9	Sensor GND
Red	10	Home position sensor
White	11	unused
Shield	12	FG

(Do not use this line)

Dotted line is the shield.

Compatible motorized stages

TALS-○○1○-G○M○
 TALD-○○1○-G○M○
 TALZ-○○1○-G○M○
 TALV-○○○○-H○M
 TARS-○○○○-○M
 TATS-○○○○-○M
 TATD-○○○○-○M
 TMSS-C series



Connection Cables ◀ Motorized Stages ▶

Driver Connection Cable

0.35 A/phase 0.35 A/phase motor

Model number	TACB-BTC-D3
Model name	Driver connection cable 3 m

■ TACB-BTC-D3 (3 m)

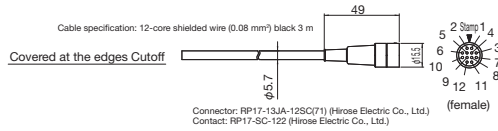

Lead color	No.	Stage side
Pink/red	1	Blue motor lead B
Pink/black	2	Red motor lead D
Orange/red	3	Orange motor lead A
Orange/black	4	Green motor lead C
Yellow/red	5	Black motor lead E
Yellow/black	6	Sensor Vcc
Gray/red	7	CCW limit
Gray/black	8	CCW limit
White/red	9	Sensor GND
White/black	10	Home position sensor
	11	unused
Shield	12	FG

Dotted line is the shield.

Compatible motorized stages

Product adopting
a 20 mm x 20 mm
0.35 A/phase stepper motor

TA○○-3○○-○M

Motorized Stages	Automated Products for Microscopes	Manual Stages	High-Grade Stages	30 mm x 30 mm (φ30 mm) Contact Stages	Class Roller Stages	Ball Bushing Stages	High-Precision/High-Rigidity Stages	Z-Lift Stages	TTR Stages	Connection Cables	Actuators
------------------	------------------------------------	---------------	-------------------	---------------------------------------	---------------------	---------------------	-------------------------------------	---------------	------------	-------------------	-----------